



(11) **EP 1 900 646 B1**

(12) **EUROPEAN PATENT SPECIFICATION**

(45) Date of publication and mention of the grant of the patent:
27.10.2010 Bulletin 2010/43

(51) Int Cl.:
B65D 27/00 (2006.01)

(21) Application number: **07016811.7**

(22) Date of filing: **28.08.2007**

(54) **Method and system for protecting privacy of signature on mail ballot utilizing optical shutter**

Verfahren und System zum Schutz der Unterzeichnerdaten auf Poststimmzetteln durch optischen Verschluss

Procédé et système pour la protection de la confidentialité d'une signature dans un bulletin de vote postal utilisant un obturateur optique

(84) Designated Contracting States:
DE FR GB

(30) Priority: **15.09.2006 US 521678**

(43) Date of publication of application:
19.03.2008 Bulletin 2008/12

(73) Proprietor: **PITNEY BOWES INC.**
Stamford, CT 06926-0700 (US)

(72) Inventors:
• **Quine, Douglas B.**
Bethel, Connecticut 06801 (US)

• **Ryan, Frederick W.**
Oxford, Connecticut 06478 (US)

(74) Representative: **HOFFMANN EITLE**
Patent- und Rechtsanwälte
Arabellastrasse 4
81925 München (DE)

(56) References cited:
US-A- 4 597 591 US-A1- 2005 061 866

EP 1 900 646 B1

Note: Within nine months of the publication of the mention of the grant of the European patent in the European Patent Bulletin, any person may give notice to the European Patent Office of opposition to that patent, in accordance with the Implementing Regulations. Notice of opposition shall not be deemed to have been filed until the opposition fee has been paid. (Art. 99(1) European Patent Convention).

Description

[0001] The invention disclosed herein relates generally to envelopes and envelope processing systems and methods. It is applicable to voting systems, and more particularly to a method and system for protecting privacy of signatures on ballots sent through the mail.

[0002] US 2005/0061866 A1 describes a voting ballot envelope having a body portion and a flap portion for covering the pocket when the flap portion is closed.

[0003] In democratic countries, governmental officials are chosen by the citizens in an election. Conducting an election and voting for candidates for public office in the United States can be performed in several different ways. One such way utilizes mechanical voting machines at predetermined polling places. When potential voters enter the predetermined polling place, voting personnel verify that each voter is properly registered in that voting district and that they have not already voted in that election. Thus, for a voter to cast his vote, he must go to the polling place at which he is registered, based on the voter's residence. Another method for conducting an election and voting utilizes paper ballots that are mailed to the voter who marks the ballot and returns the ballot through the mail. Mailed ballots have been historically reserved for absentee voting. In the usual absentee voting process, the voter marks the ballot to cast his/her vote and then inserts the ballot in a return envelope which is typically pre-addressed to the voter registrar office in the corresponding county, town or locality in which the voter is registered. The voter typically appends his/her signature on the back of the envelope adjacent his/her human or machine readable identification.

[0004] When the return envelope is received at the registrar's office, a voting official compares the voter signature on the envelope with the voter signature retrieved from the registration file to make a determination as to whether or not the identification information and signature are authentic and valid, and therefore the vote included in the envelope should be counted. If the identification information and signature are deemed to be authentic and valid, the identifying information and signature are separated from the sealed ballot before it is handed to the ballot counters for tabulation. In this manner, the privacy of the voter's selections is maintained and thus the ballot remains a "secret ballot."

[0005] One general problem with vote by mail envelopes is the signature is in the open and exposed for all to see throughout the process for determining whether or not the vote is authentic. This leads to potential privacy issues and concerns, e.g., fraudulent usage of a voter's signature. Some jurisdictions have required that such signatures be hidden from plain sight while the envelope is en route from the voter to the registrar's office. This will protect against easy imaging of the signature, such as, for example, with a hand scanner or digital camera, for later impersonation or other fraudulent purposes, e.g., identity theft. To comply with such requirements, enve-

lopes have been proposed that hide the signature with a flap which is removed when the envelope is received at the registrar's office. These solutions, however, require some mechanical manipulation of the envelopes, which is both expensive and increases the risk of accidental tears of the envelope, potentially leading to damage to the ballots contained in the envelopes and subsequently errors in the counting of votes.

[0006] Voting by mail is becoming more prevalent, apart from the usual absentee voting, and in some jurisdictions, entire elections are being conducted exclusively by mail. As the voting by mail becomes more prevalent, the privacy concerns are also more prevalent. Thus, there exists a need for efficient methods and systems that can protect the privacy of signatures on ballots sent through the mail while also reducing the risk of damage to the ballots when the signatures are revealed.

[0007] The present invention alleviates the problems associated with the prior art and provides methods and systems that protect the privacy of signatures on ballots sent through the mail while also reducing the risk of damage to the ballots when the signatures are revealed.

[0008] According to a first aspect of the invention, there is provided an envelope comprising: a body portion including a pocket for holding contents, the body portion including a predefined area for information to be provided on the body portion; a flap portion connected to the body portion for covering the pocket when the flap portion is in a closed position, characterized by: the flap portion including an opening that corresponds with the predefined area of the body portion when the flap is in the closed position such that the information in the predefined area is not covered by the flap portion; and an optical shutter covering the opening, the optical shutter having a first state in which the information in the predefined area is concealed and a second state in which the information in the predefined area is not concealed, the optical shutter operable to change from the first state to the second state upon application of a voltage signal to the optical shutter.

[0009] According to a second aspect of the invention, there is provided a system for processing an envelope according to the first aspect, the system comprising: a transport for transporting the envelope through the system; a power supply for supplying the voltage signal; a plurality of electrical contacts coupled to the power supply and positioned such that each of the electrical contacts will make contact with a respective conductive trace as the envelope is transported past the electrical contacts to apply the voltage signal to the optical shutter to cause the optical shutter to change from the first state to the second state; and a reading device to read the information in the predefined area of the envelope when the optical shutter is in the second state and the information is not concealed.

[0010] According to a third aspect of the invention, there is provided a method for processing a ballot received from a voter in an envelope according to the first

aspect, the method comprising: applying a voltage signal to the optical shutter to cause the optical shutter to change from the first state to a second state in which the information is not concealed by the optical shutter; reading the information from the envelope; comparing the information read from the envelope with reference information to determine authenticity of the ballot; and if the information read from the envelope compares favorably with the reference information, accepting the ballot as authentic.

[0011] Therefore, it should now be apparent that the invention substantially achieves all the above aspects and advantages. Additional aspects and advantages of the invention will be set forth in the description that follows, and in part will be obvious from the description, or may be learned by practice of the invention. Moreover, the aspects and advantages of the invention may be realized and obtained by means of the instrumentalities and combinations particularly pointed out in the appended claims.

[0012] The accompanying drawings illustrate presently preferred embodiments of the invention, and together with the general description given above and the detailed description given below, serve to explain the principles of the invention. As shown throughout the drawings, like reference numerals designate like or corresponding parts. In the drawings:

FIG. 1 illustrates an envelope for returning ballots by mail according to an embodiment of the present invention in an open position;

FIG. 2 illustrates the envelope of Fig. 1 in a closed position;

FIG. 3 illustrates in schematic form an optical shutter and conductive rails according to an embodiment of the present invention;

FIG. 4 illustrates in block diagram form a system for viewing the signature concealed using the envelope illustrated in Figs. 1 and 2 according to an embodiment of the present invention; and

FIG. 5 illustrates in flow diagram form the preparation and processing of an envelope for mailing a ballot according to an embodiment of the present invention.

[0013] The following describes an envelope for returning ballots by mail which includes an electronic optical shutter that covers an opening in the flap of the envelope. The voter signs the back of the envelope in an area that will be visible through the opening in the flap (covered by the optical shutter) when the envelope flap is sealed. The optical shutter is opaque under static conditions, but will become transparent when appropriate power is supplied to it. Thus, when the envelope flap is sealed and no power is applied to the optical shutter, the voter's signature will be concealed by the optical shutter. Upon receipt at the registrar's office (or other official vote tallying location), the optical shutter can be powered, thereby

rendering the optical shutter transparent, and the voter's signature can be viewed for comparison with the official records to perform the required signature verification to determine validity and authenticity of the ballot. Preferably, the envelope flap is provided with conductive power rails that will allow power to be supplied to the optical shutter while the envelope is being processed by automated mail processing equipment. Thus, while the envelope is en route from the voter to the registrar's office, the voter's signature will be concealed from plain view. Viewing of the signature does not require any mechanical manipulation of the envelope or flaps on the envelope, thereby reducing the processing cost and the risk of causing damage to the ballot contained therein. After verification of the voter's signature, the ballot can be separated from the envelope and provided to the ballot counters for tabulation. Optionally, the optical shutter can be reused on subsequent envelopes.

[0014] Reference is now made to the drawings, wherein there is seen in Fig. 1 an envelope 10 for returning ballots by mail according to an embodiment of the present invention in an open position. While the present description is directed to an envelope for returning ballots by mail, it should be understood that the invention is not so limited and the envelope 10 could be used to hold any type of communication or material. Envelope 10 includes a body portion 12 and a flap portion 14 connected to the body portion 12. When the flap portion 14 is in an open position as illustrated in Fig. 1, contents, such as, for example, a ballot, can be inserted into a pocket 18 formed by the body portion 12. The flap portion 14 can then be moved to a closed position (as illustrated in Fig. 2), and sealed utilizing a glue or sealing strip 16 which when activated will adhere the flap portion 14 to the body portion 12, thereby covering the pocket 18 and preventing the contents therein from falling out.

[0015] The body portion 12 is provided with an area 20 intended for the voter's signature along with an area 22 in which information that identifies the voter is provided. Such information can include, for example, the voter's name and address, and is preferably provided in some machine readable form such as a barcode. The identification information is preferably preprinted on the body portion 12 of the envelope 10, or alternatively may be preprinted on an adhesive label that the voter applies to the body portion 12 in the area 22.

[0016] The flap portion includes an opening 30 (indicated by the dashed lines in Fig. 1) that corresponds with the areas 20, 22 of the body portion when the flap portion 14 is in the closed position. An optical shutter 32 is placed such that the optical shutter 32 covers the opening 30. As shown in Fig. 2, when the flap portion 14 is folded over the body portion 12, the optical shutter 32 covers the areas 20, 22 on the body portion 12 of the envelope 10. Since the sealing strip 16 preferably extends along the sides of the flap portion 14, access to the areas 20, 22 is prevented through the side of the flap portion 14. The optical shutter 32 has two states, transparent and

opaque. When the optical shutter 32 is opaque, it will conceal the information contained in the areas 20, 22 on the body portion 12 of the envelope 10. When the optical shutter 32 is transparent, the information contained in the areas 20, 22 of the body portion 12 is not concealed and can be read (through the opening 30 and optical shutter 32). An example of an optical shutter 32 is a liquid crystal display shutter, such as is available from Liquid Crystal Technologies, Cleveland, Ohio. The state of the optical shutter 32 is changed by applying voltage to the optical shutter 32, preferably through a pair of conductive traces, such as, for example, conductive rails 40, 42, as described below.

[0017] Fig. 3 illustrates in schematic form an optical shutter 32 in the form of a liquid crystal display and conductive rails 40, 42 according to an embodiment of the present invention. While the structure and operation of a liquid crystal display is well known in the art and need not be described in detail for an understanding of the present invention, a general description of the structure and operation will be provided. Optical shutter 32 includes a layer of nematic liquid crystals 52 sandwiched between two clear polarized substrates 44, 46, such as, for example, glass that has a polarizing film applied to the side facing outward away from the layer 52, oriented such that the polarizing films are in the same direction. The side of the substrate 44 that does not have the polarizing film (facing toward the layer 52) has microscopic grooves in the surface that are oriented at a ninety degree angle to the polarizing film. The side of the substrate 46 that does not have the polarizing film (facing toward the layer 52) has microscopic grooves in the surface that are in the same direction as the polarizing film. A common electrode plane 48, formed from, for example, indium-tin oxide, is provided on the side of the substrate 44 with the grooves. Common electrode plane 48 is connected to a first conductive rail 42. A segment electrode plane 50, which can also be formed, for example, from indium-tin oxide, is provided on the side of the substrate 46 with the grooves. Segment electrode plane 50 is connected to a second conductive rail 40 (described further below). The molecules of the first layer of nematic liquid crystals 52 closest to the substrate 44 will align with the grooves in the substrate 44, thereby aligning at a ninety degree angle to the polarizing, orientation of the substrate 44. Each successive layer of molecules of the nematic liquid crystals 52 will gradually twist until the uppermost layer closest to the substrate 46 is at a ninety-degree angle to the bottom layer, thereby matching the polarizing orientation of the substrate 46.

[0018] As light traveling in the direction indicated by the arrow 56 strikes the first substrate 46, it is polarized in the polarizing orientation of the substrate 46 and passed through. The molecules in each layer of the nematic liquid crystals 52 guide the light to each successive layer. As light passes through each molecule, the orientation of the light is changed to match the plane of each molecule. When the light reaches the final layer of

molecules in the nematic liquid crystals 52, its orientation is at the same angle as the final layer of molecules, which is at a ninety degree angle to the polarizing orientation of the substrate 44. As such, the light will not pass through the substrate 44 and the optical shutter 32 will appear as a dark area, i.e., opaque. When a voltage is applied between the common electrode plane 48 and the segment electrode plane 50, thereby passing a current through the nematic liquid crystals 52, the nematic liquid crystals 52 will untwist. The untwisting of the nematic liquid crystals 52 will change the angle of the light passing through them, aligning the orientation of the light to match the polarizing orientation of the substrate 44. As such, with a voltage applied to the planes 48, 50, light will pass through the substrate 44 and the optical shutter 32 will appear transparent.

[0019] The use of the conductive rails 40, 42 according to the present invention eliminates the need for individual power supplies associated with each optical shutter 32. The conductive rails 40, 42 can be utilized to provide the necessary power to the optical shutter 32 as the envelope 10 is being processed by automated processing equipment. The conductive rails 40, 42 are preferably applied to the surface of the substrate 46 or to the body portion 12 with connections to the applicable plane 48, 50. The conductive rail 40 is preferably provided with alternating contacts 54, the reason for which described below. Fig. 4 illustrates in block diagram form an automated system 60 for viewing the signature concealed using an optical shutter 32 and envelope 10 illustrated in Figs. 1-3 according to an embodiment of the present invention. System 60 includes a control unit 62, such as, for example, a general or special purpose microprocessor or the like, that controls operation of the system 60. Control unit 62 is connected to a database 74, which is used to store voter information, including, for example, name, address, and a reference signature for use in verifying ballots received by mail as described below. A transport 64, such as, for example, rollers and/or belts, is used to transport a series of envelopes 10 (only one shown in Fig. 4) through the system 60. The speed of the transport 64 is preferably controlled by the control unit 62. A reading device 66, such as, for example, a scanner, camera, or the like is positioned adjacent to the transport 64 such that information provided on envelopes 10 being transported past the reading device 66 can be read therefrom. A diverter 76 is located downstream from the reading device 66 and is coupled to the control unit 62. Based on command signals from the control unit 62, the diverter 76 will divert each envelope to a reject path 78 or an accept ballot path 80 as described below.

[0020] The system 60 will apply a voltage from voltage supply source 68 to the optical shutter 32 of each envelope being transported therethrough, thereby rendering the optical shutter 32 transparent and allowing the reading device 66 to read each voter's signature located under the optical shutter 32. The voltage applied between the common electrode plane 48 and segment electrode

plane 50 is preferably an AC RMS voltage with a minimal (approximately 50 mv or less) DC offset, as a DC voltage will cause damage to the nematic liquid crystals 52 which will eventually destroy them. Thus, the voltage source 68 may be an AC voltage source and the rails 40, 42 may be continuous rails. It is preferable to apply a square wave voltage signal to the common plane 48 and segment plane 50. While a purely AC signal (with no DC offset) can easily be generated, it is preferable for the voltage supply 68 to be a DC voltage source, that, coupled with the alternating contacts 54 of the conductive rail 40 (see Fig. 3), will result in the application of an AC square wave to the optical shutter 32. Voltage supply 68 is coupled to a pair of contacts 72a, 72b which are secured by a contact holder 70. The contacts 72a, 72b are preferably finger like projections that extend into the path of travel of the envelopes 10. The contacts 72a, 72b preferably include a biasing means, such as, for example, a spring or the like (not shown), to bias them towards the transport 64, thereby ensuring suitable contact between the contacts 72a, 72b and an envelope 10 passing underneath. Each contact 72a, 72b aligns with a respective conductive rail 40, 42 such that as the envelope 10 passes beneath the contact holder 70, the contacts 72a, 72b make a conductive connection to the conductive rails 40, 42 and allow voltage from the voltage supply 68 to be applied to the conductive rails 40, 42. The length of the alternating pattern of contacts 54, the space between each contact 54, and the speed of the transport 64 can be used to control the drive frequency of the square wave applied to each optical shutter 32. Preferably, the drive frequency is in the range of 40 to 60 Hz.

[0021] Fig. 5 illustrates in flow diagram form the preparation and processing of an envelope 10 for mailing a ballot according to an embodiment of the present invention. In step 100, a voter completes a ballot and inserts it into the pocket 18 of envelope 10. In step 102, the voter signs the envelope 10 in the signature area 20. In step 104, the voter seals the flap portion 14 to the body portion 12 of the envelope 10, thereby covering the identification area 22 and signature area 20 with the optical shutter 32, and mails the envelope 10 to the registrar's office. Since the optical shutter 32 is not provided with any power, it will appear opaque, as described above, and the signature and identification located in the areas 22 and 20 will be hidden from view. Thus, the privacy of the voter's signature is maintained during transit of the envelope 10 from the voter to the registrar's office.

[0022] Upon receipt of the envelope 10 at the registrar's office, in step 106 the envelope 10 is processed using the system as illustrated in Fig. 4. The envelope 10 is transported by the transport 64 and a voltage is applied to the conductive rails 40, 42 via the contacts 72a, 72b, thereby rendering the optical shutter 32 transparent as described above. The reading device 66 can then read the identification information in area 22 and the signature in area 20 from the envelope 10. In step 108, the control unit 62 will retrieve the reference signa-

ture from the database 74, based on the identification of the voter in area 22, and compare the reference signature to the signature read from area 20 of envelope 10. In step 110, it is determined if the reference signature retrieved from the data base 74 corresponds to the signature read from area 20 of envelope 10. If the signatures do not correspond, then in step 112 the ballot is rejected as not being verified and the envelope 10 is diverted by the diverter 76 to the reject path 78. Envelopes diverted to the reject path may be subject to some type of investigation to make a final determination if the vote should be counted or not. If in step 110 it is determined that the signatures do correspond, then in step 114 the ballot is deemed to be authentic and verified and the envelope 10 is diverted by the diverter 76 to the accept ballot path 80, in which the ballot will be given to ballot counters for tabulation. Preferably, the ballot is removed from the envelope 10 before being given to the ballot counters thereby maintaining a "secret ballot." Optionally, in step 116, the optical shutter 32 is removed from the envelope 10 (regardless of whether the vote was counted in step 114 or not counted in step 112) for reuse in subsequent elections. **[0023]** Thus, according to the present invention, methods and systems that protect the privacy of signatures on ballots sent through the mail are provided. While preferred embodiments of the invention have been described and illustrated above, it should be understood that these are exemplary of the invention and are not to be considered as limiting. Accordingly, the invention is not to be considered as limited by the foregoing description but is only limited by the scope of the appended claims.

35 Claims

1. An envelope (10) comprising:

a body portion (12) having a pocket (18) for holding contents, the body portion including a predefined area (20) for information to be provided on the body portion;

a flap portion (14) connected to the body portion (12) for covering the pocket (18) when the flap portion is in a closed position, **characterized by:**

the flap portion including an opening (30) that corresponds with the predefined area (20) of the body portion when the flap is in the closed position such that the information in the predefined area is not covered by the flap portion; and

an optical shutter (32) covering the opening (30), the optical shutter (32) having a first state in which the information in the predefined area is concealed and a second state in which the information in the predefined

- area is not concealed, the optical shutter operable to change from the first state to the second state upon application of a voltage signal to the optical shutter.
2. The envelope according to Claim 1, wherein the predefined area (20) includes at least one of an area (20) for a person's signature, and an area (22) for identification information of the person.
 3. The envelope according to Claim 1, further comprising:
 - a first conductive trace (40) coupled to the optical shutter; and
 - a second conductive trace (42) coupled to the optical shutter;
 - wherein the voltage signal is applicable to the first and second conductive traces to change the optical shutter from the first state to the second state.
 4. A system (60) for processing an envelope according to any preceding claim, the system comprising:
 - a transport (64) for transporting the envelope (10) through the system;
 - a power supply (68) for supplying the voltage signal;
 - a plurality of electrical contacts (72a, 72b) coupled to the power supply (68) and positioned such that each of the electrical contacts will make contact with a respective conductive trace (40, 42) as the envelope is transported past the electrical contacts to apply the voltage signal to the optical shutter to cause the optical shutter to change from the first state to the second state; and
 - a reading device (66) to read the information in the predefined area of the envelope when the optical shutter is in the second state and the information is not concealed.
 5. The system according to Claim 4, further comprising:
 - a control unit (62) for comparing at least a portion of the information read from the envelope with reference information and generating a result;
 - a diverter device (76) coupled to the control unit (62) to divert the envelope to a selected path based on the result of the comparison of the information read from the envelope with the reference information; and
 - a data base (74) coupled to the control unit (62), the data base for storing the reference information.
 6. A method for processing a ballot received from a voter in an envelope (10) according to any one of Claims 1 to 3, the method comprising:
 - applying (106) a voltage signal to the optical shutter to cause the optical shutter (32) to change from the first state to a second state in which the information is not concealed by the optical shutter;
 - reading (106) the information from the envelope (10);
 - comparing (108) the information read from the envelope with reference information to determine authenticity of the ballot; and
 - if the information read from the envelope compares favorably with the reference information, accepting (114) the ballot as authentic.
 7. The method according to Claim 6, wherein the information read from the envelope includes a signature of the voter and the reference information includes a reference signature.
 8. The method according to Claim 7, wherein the information read from the envelope further includes identification information associated with the voter; and the method further comprises:
 - obtaining the reference signature from a data base based on the identification information associated with the voter that is read from the envelope.
 9. The method according to Claim 6, wherein applying a voltage signal further comprises:
 - applying a DC voltage signal between a first conductive rail (40) coupled to the optical shutter (32) and a second conductive rail (42) having a pattern of alternating contacts coupled to the optical shutter (32).

Patentansprüche

1. Umschlag (10), welcher umfasst:
 - einen Hauptteil (12) mit einer Tasche (18) zum Halten von Inhalten, wobei der Hauptteil eine vordefinierte Fläche (20) zum Bereitstellen von Information auf dem Hauptteil beinhaltet;
 - einen Klappteil (14), welcher mit dem Hauptteil (12) verbunden ist, zum Bedecken der Tasche (18), wenn der Klappteil in einer geschlossenen Position ist, **dadurch gekennzeichnet, dass:**
 - der Klappteil eine Öffnung (30) beinhaltet, welche mit der vordefinierten Fläche (20) des Hauptteils übereinstimmt, wenn sich

- die Klappe in der geschlossenen Position befindet, so dass die Information in der vordefinierten Fläche nicht von dem Klappteil bedeckt wird; und
 ein optischer Verschluss (32) die Öffnung (30) bedeckt, wobei der optische Verschluss (32) einen ersten Zustand hat, bei welchem die Information in der vordefinierten Fläche verborgen ist und einen zweiten Zustand, bei welchem die Information in der vordefinierten Fläche nicht verborgen ist, wobei der optische Verschluss betreibbar ist, von dem ersten Zustand in den zweiten Zustand nach Anlegen eines Spannungssignals an den optischen Verschluss zu wechseln.
2. Umschlag nach Anspruch 1, wobei die vordefinierte Fläche (20) wenigstens eine Fläche (20) für eine Unterschrift einer Person oder eine Fläche (22) für Identifikationsinformation der Person beinhaltet.
3. Umschlag nach Anspruch 1, welcher ferner umfasst:
 eine erste leitende Spur (40), welche an den optischen Verschluss gekoppelt ist; und
 eine zweite leitende Spur (42), welche an den optischen Verschluss gekoppelt ist;
 wobei das Spannungssignal an die ersten und zweiten leitenden Spuren angelegt werden kann, um den optischen Verschluss von dem ersten Zustand in den zweiten Zustand zu wechseln.
4. System (60) zum Verarbeiten eines Umschlags nach einem vorangehenden Anspruch, wobei das System umfasst:
 eine Beförderung (64), um den Umschlag (10) durch das System zu befördern;
 eine Leistungsversorgung (68) zum Bereitstellen des Spannungssignals;
 eine Vielzahl an elektrischen Kontakten (72a, 72b), welche an die Leistungsversorgung (68) gekoppelt sind und so positioniert, dass jeder elektrische Kontakt eine jeweilige leitende Spur (40, 42) berühren wird, wenn der Umschlag an den elektrischen Kontakten vorbei befördert wird, um das Spannungssignal an den optischen Verschluss anzulegen, um zu bewirken, dass der optische Verschluss von dem ersten Zustand in den zweiten Zustand wechselt;
 und
 eine Lesevorrichtung (66) zum Lesen der Information in der vordefinierten Fläche des Umschlags, wenn der optische Verschluss in dem zweiten Zustand ist und die Information nicht verborgen wird.
5. System nach Anspruch 4, welches ferner umfasst:
 eine Steuerungseinheit (62) zum Vergleichen von wenigstens einem Teil der Information, welche aus dem Umschlag gelesen wird, mit Referenzinformation und zum Erzeugen eines Resultats;
 eine Umleitevorrichtung (76), welche an die Steuerungseinheit (62) gekoppelt ist, um den Umschlag auf einen gewählten Pfad umzuleiten, basierend auf dem Resultat des Vergleichs der Information, welche aus dem Umschlag gelesen wird, mit der Referenzinformation; und
 eine Datenbank (74), welche an die Steuerungseinheit (62) gekoppelt ist, wobei die Datenbank dem Speichern der Referenzinformation dient.
6. Verfahren zum Verarbeiten eines Stimmzettels, welcher von einem Wähler in einem Umschlag (10) empfangen wird, nach einem der Ansprüche 1 bis 3, wobei das Verfahren umfasst:
 Anlegen (106) eines Spannungssignals an den optischen Verschluss, um zu bewirken, dass der optische Verschluss (32) von dem ersten Zustand zu einem zweiten Zustand wechselt, in welchem die Information durch den optischen Verschluss nicht verborgen wird;
 Lesen (106) der Information aus dem Umschlag (10);
 Vergleichen (108) der Information, welche aus dem Umschlag gelesen wird, mit Referenzinformation, um die Echtheit des Stimmzettels zu bestimmen; und
 falls die Information, welche aus dem Umschlag gelesen wird, sich vorteilhaft mit der Referenzinformation vergleicht, Akzeptieren (114) des Stimmzettels als echt.
7. Verfahren nach Anspruch 6, wobei die Information, welche aus dem Umschlag gelesen wird, eine Unterschrift des Wählers beinhaltet und die Referenzinformation eine Referenzunterschrift beinhaltet.
8. Verfahren nach Anspruch 7, wobei die Information, welche aus dem Umschlag gelesen wird, ferner Identifikationsinformation beinhaltet, welche mit dem Wähler assoziiert ist; und das Verfahren ferner umfasst:
 Erhalten der Referenzunterschrift aus einer Datenbank, basierend auf der Identifikationsinformation, welche mit dem Wähler assoziiert ist, welche aus dem Umschlag gelesen wird.
9. Verfahren nach Anspruch 6, wobei Anlegen eines Spannungssignals ferner umfasst:

Anlegen eines Gleichspannungssignals zwischen einer ersten leitenden Schiene (40), welche an den optischen Verschluss (32) gekoppelt ist, und einer zweiten leitenden Schiene (42), mit einem Muster von abwechselnden Kontakten, welche an den optischen Verschluss (32) gekoppelt ist.

Revendications

1. Enveloppe (10) comprenant :

une partie formant corps (12) ayant une poche (18) destinée à renfermer un contenu, la partie formant corps comprenant une zone prédéfinie (20) pour que des informations soient fournies sur la partie formant corps ;

une partie formant rabat (14) reliée à la partie formant corps (12) pour recouvrir la poche (18) lorsque la partie formant rabat est dans une position fermée, **caractérisée par**

la partie formant rabat comprenant une ouverture (30) qui correspond à la zone prédéfinie (20) de la partie formant corps lorsque le rabat est dans la position fermée de manière que les informations dans la zone prédéfinie ne soient pas recouvertes par la partie formant rabat ; et un obturateur optique (32) recouvrant l'ouverture (30), l'obturateur optique (32) ayant un premier état dans lequel les informations dans la zone prédéfinie sont cachées et un deuxième état dans lequel les informations dans la zone prédéfinie ne sont pas cachées, l'obturateur optique étant apte à passer du premier état au deuxième état lors de l'application d'un signal de tension à l'obturateur optique.

2. Enveloppe selon la revendication 1, dans laquelle la zone prédéfinie (20) comprend au moins une zone (20) pour la signature d'une personne, et une zone (22) pour les informations d'identification de la personne.

3. Enveloppe selon la revendication 1, comprenant, en outre :

un premier tracé conducteur (40) couplé à l'obturateur optique ; et

un deuxième tracé conducteur (42) couplé à l'obturateur optique ;

où le signal de tension est applicable aux premier et deuxième tracés conducteurs pour faire passer l'obturateur optique du premier état au deuxième état.

4. Système (60) pour traiter une enveloppe selon l'une quelconque des revendications précédentes, le sys-

tème comprenant :

un dispositif de transport (64) pour transporter l'enveloppe (10) à travers le système ;

une alimentation électrique (68) pour fournir le signal de tension ;

une pluralité de contacts électriques (72a, 72b) couplés à l'alimentation électrique (68) et positionnés de manière que chacun des contacts électriques fasse contact avec un tracé conducteur (40, 42) respectif tandis que l'enveloppe est transportée au-delà des contacts électriques pour appliquer le signal de tension à l'obturateur optique afin d'amener l'obturateur optique à passer du premier état au deuxième état ; et un dispositif de lecture (66) pour lire les informations dans la zone prédéfinie de l'enveloppe lorsque l'obturateur optique est dans le deuxième état et les informations ne sont pas cachées.

5. Système selon la revendication 4, comprenant, en outre :

une unité de commande (62) pour comparer au moins une partie des informations lues depuis l'enveloppe avec des informations de référence et produire un résultat ;

un dispositif d'aiguillage (76) couplé à l'unité de commande (62) pour aiguiller l'enveloppe vers un passage sélectionné sur la base du résultat de la comparaison des informations lues depuis l'enveloppe avec les informations de référence ; et

une base de données (74) couplée à l'unité de commande (62), la base de données servant à stocker les informations de référence.

6. Procédé de traitement d'un bulletin de vote reçu d'un votant dans une enveloppe (10) selon l'une quelconque des revendications 1 à 3, le procédé comprenant :

l'application (106) d'un signal de tension à l'obturateur optique afin d'amener l'obturateur optique (32) à passer du premier état à un deuxième état dans lequel les informations ne sont pas cachées par l'obturateur optique ;

la lecture (106) des informations depuis l'enveloppe (10) ;

la comparaison (108) des informations lues depuis l'enveloppe avec les informations de référence afin de déterminer l'authenticité du bulletin de vote ; et

si les informations lues depuis l'enveloppe concordent avec les informations de référence, l'acceptation (114) du bulletin de vote comme authentique.

7. Procédé selon la revendication 6, dans lequel les informations lues depuis l'enveloppe comprennent une signature du votant et les informations de référence comprennent une signature de référence.

5

8. Procédé selon la revendication 7, dans lequel les informations lues depuis l'enveloppe comprennent, en outre, des informations d'identification associées au votant ; et le procédé comprend, en outre :

10

l'obtention de la signature de référence à partir d'une base de données sur la base des informations d'identification associées au votant qui sont lues depuis l'enveloppe.

15

9. Procédé selon la revendication 6, dans lequel l'application d'un signal de tension comprend, en outre :

l'application d'un signal de tension en courant continu entre un premier rail conducteur (40) couplé à l'obturateur optique (32) et un deuxième rail conducteur (42) ayant un motif de contacts alternatifs couplés à l'obturateur optique (32).

20

25

30

35

40

45

50

55

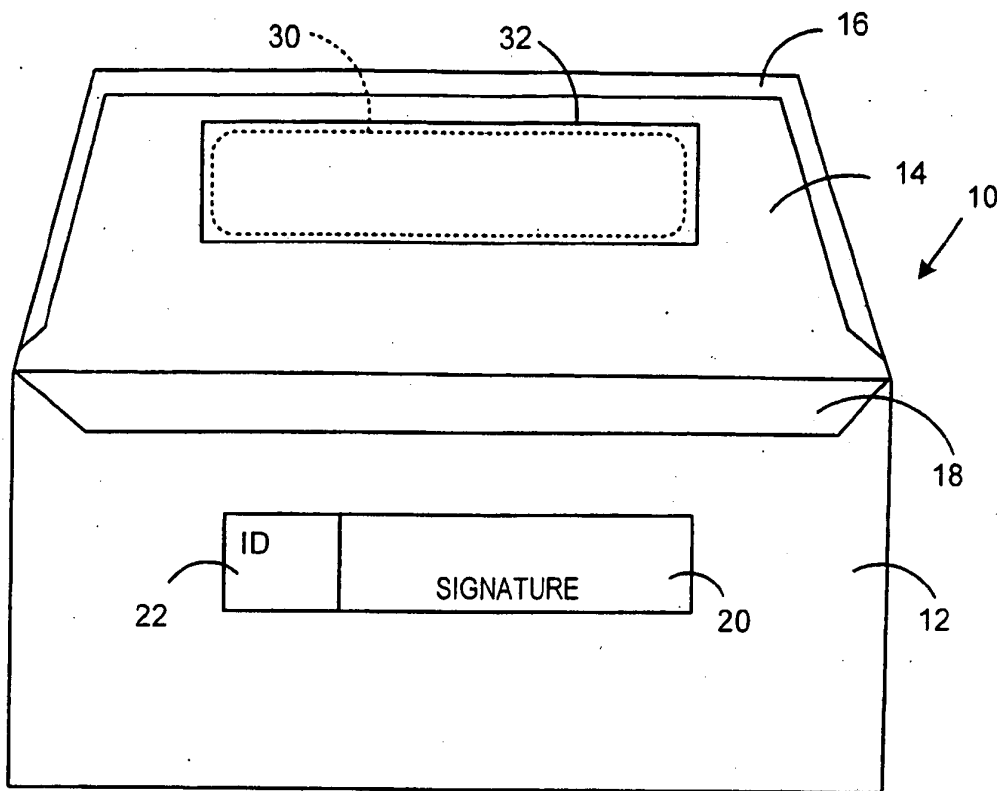

FIG. 1

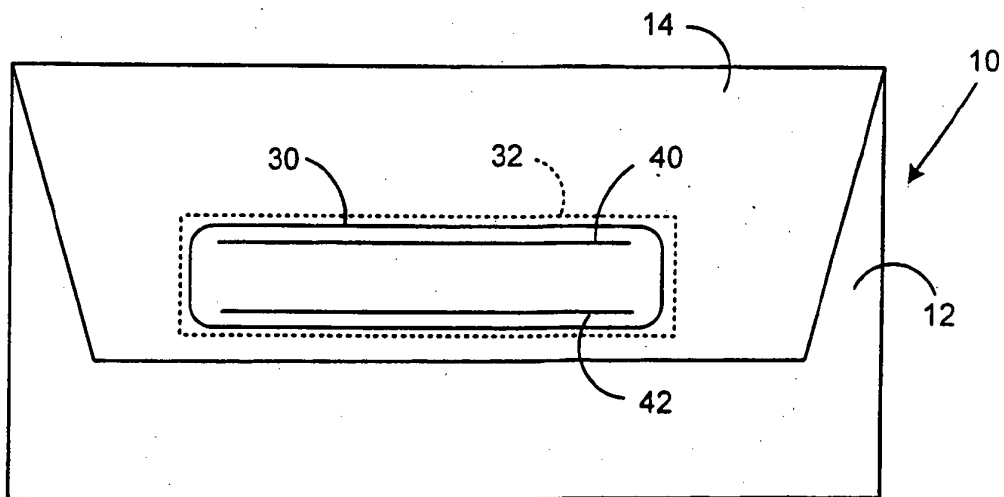

FIG. 2

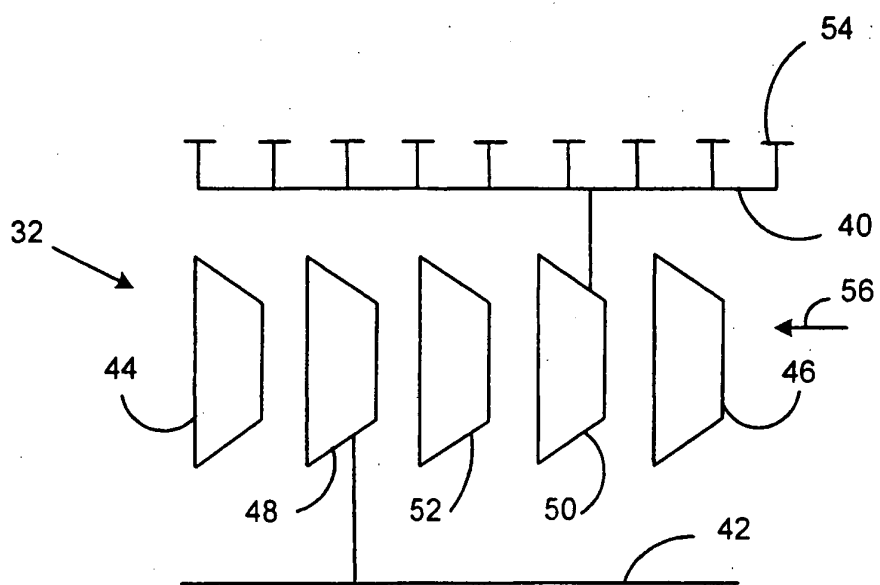

FIG. 3

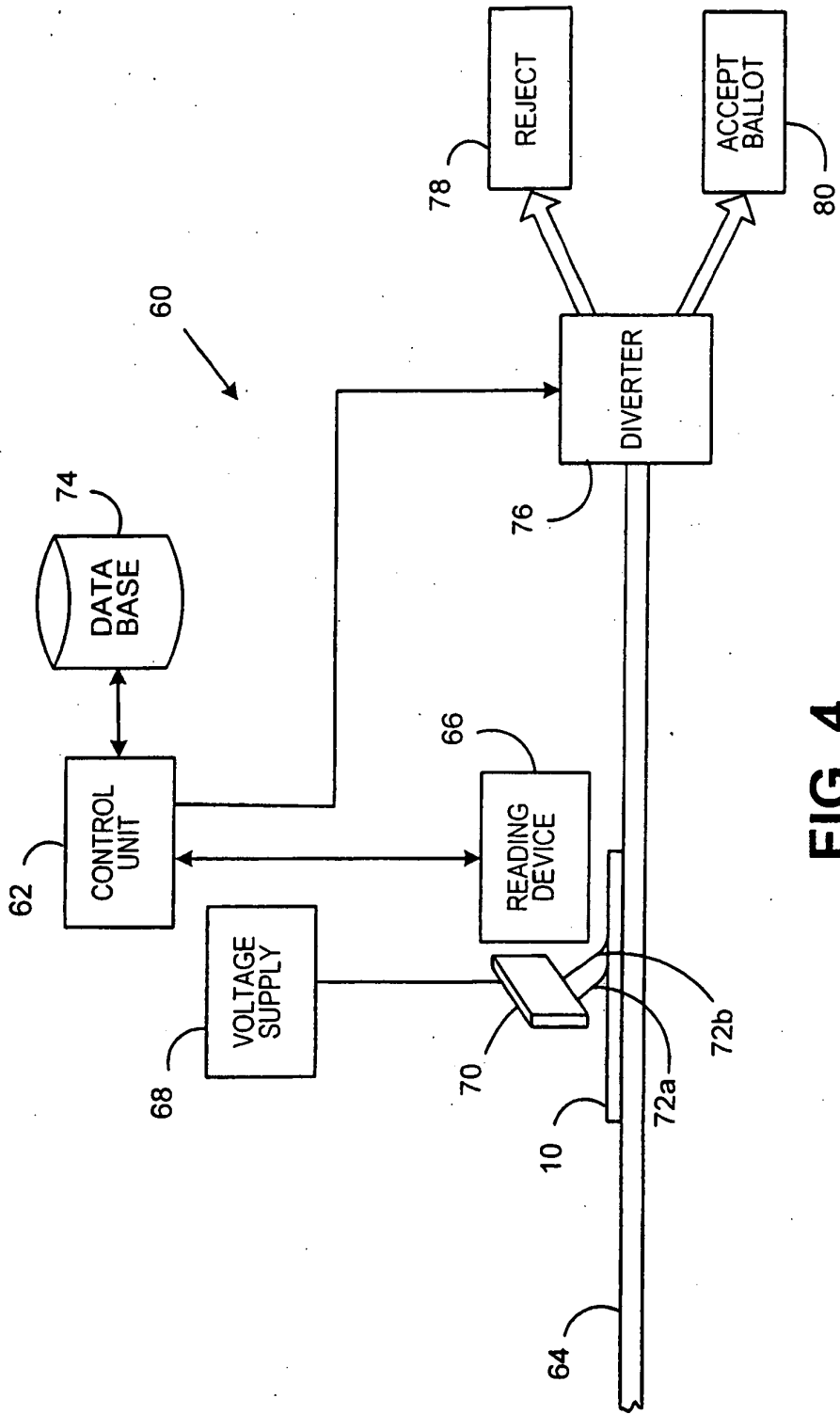

FIG. 4

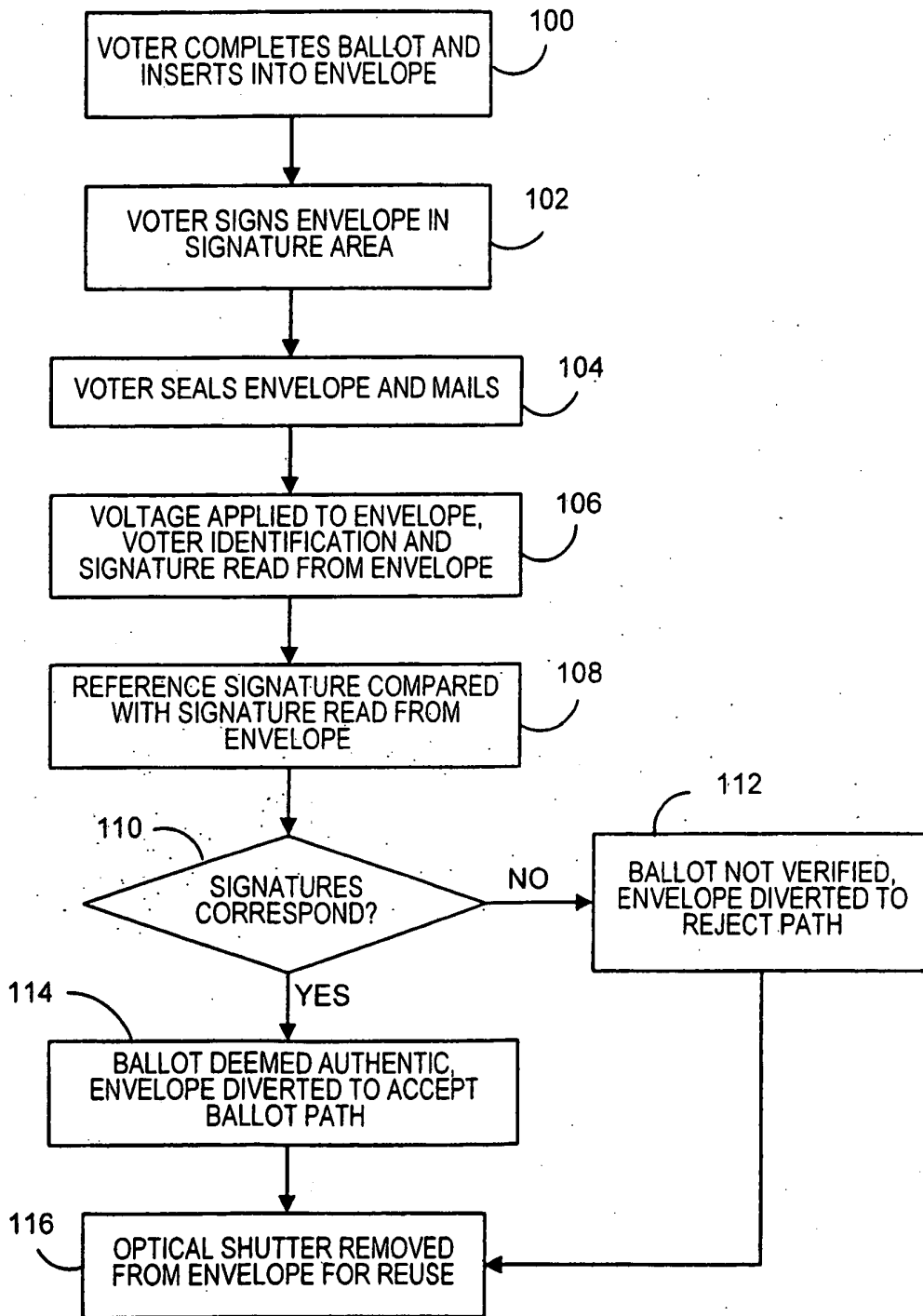

FIG. 5

REFERENCES CITED IN THE DESCRIPTION

This list of references cited by the applicant is for the reader's convenience only. It does not form part of the European patent document. Even though great care has been taken in compiling the references, errors or omissions cannot be excluded and the EPO disclaims all liability in this regard.

Patent documents cited in the description

- US 20050061866 A1 [0002]